

APPLICATIONS
APPLICATIONS
TOEPASSINGEN
ANWENDUNGEN



Katana Ultra Slims Ultra Slims

- Easy to change the poster
- Ultra slim
- Long life fluorescent lamps
- Even spread of light
- Low energy consumption
- Single or double sided
- Indoor usage
- Easy to install / easy to handle
- Long life, high quality
- Different possible colour finishes
- Possible branding with logo
- Modern and neutral design



APPLICATIONS
 APPLICATIONS
 TOEPASSINGEN
 ANWENDUNGEN

SPECIFICATIONS
 SPÉCIFICATIONS
 SPECIFICATIES
 SPEZIFIKATIONEN



1 spring ressort bladveer Blattfeder	2 click profile (alu anodised) profilé clic (alu anodisé) klikprofiel (geanodiseerd alu) Klappprofil (Alu eloxiert)
3 reflector profile (alu) profil reflecteur (alu) lampreflectorprofiel (alu) Reflektorprofil (Alu)	4 edge lit panel (PMMA) diffuseur (PMMA) centrale lichtplaat (PMMA) Lichtstreuplatte (PMMA)
5 back panel (alu 1 mm) panneau de dos (alu 1 mm) rugpaneel (alu 1 mm) Rückwand (1 mm Alu)	6 cover sheet (PC anti-glare) feuille de protection (PC anti-reflet) beschermfolie (PC anti-reflex) Schutzfolie (PC antireflex)
7 fluorescent tube (T5) tube TL (T5) TL-lamp (T5) Leuchtstoffröhre (T5)	8 electronic ballast ballast électronique electronische ballast elektronisches Vorschaltgerät
9 base profile (alu anodised) profilé de base (alu anodisé) basisprofiel (geanodiseerd alu) Trägerprofil (Alu eloxiert)	

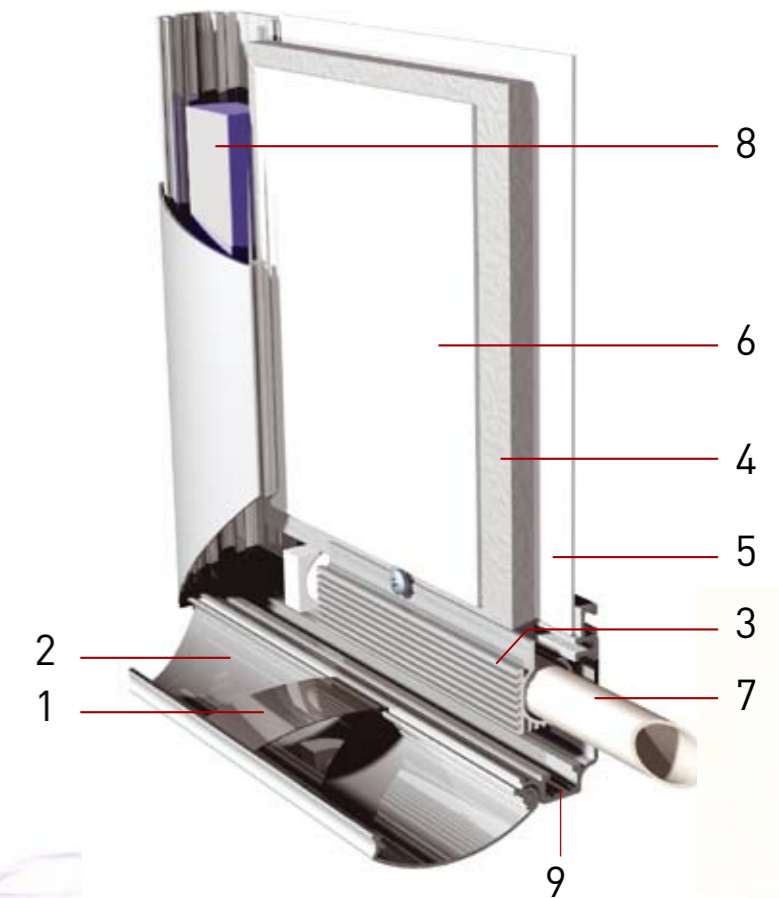

	48 SEMI CURVED/FLAT	56 SEMI CURVED/STRAIGHT
PROFILE WIDTH	48 mm	56 mm
VISIBLE SIZE	poster size - 13 mm	poster size - 14 mm
OVERALL SIZE	poster size + 83 mm	poster size + 98 mm
POWDER COATED PROFILES ON DEMAND		
POSTER SIZE	A4	A1
	A3	600x800mm
	A2	A0
	400x600mm	800x1200mm
	500x700mm	700x1000mm
DEPTH	single sided 35 mm	single sided 37 mm
DEPTH	double sided 44 mm	double sided 46 mm

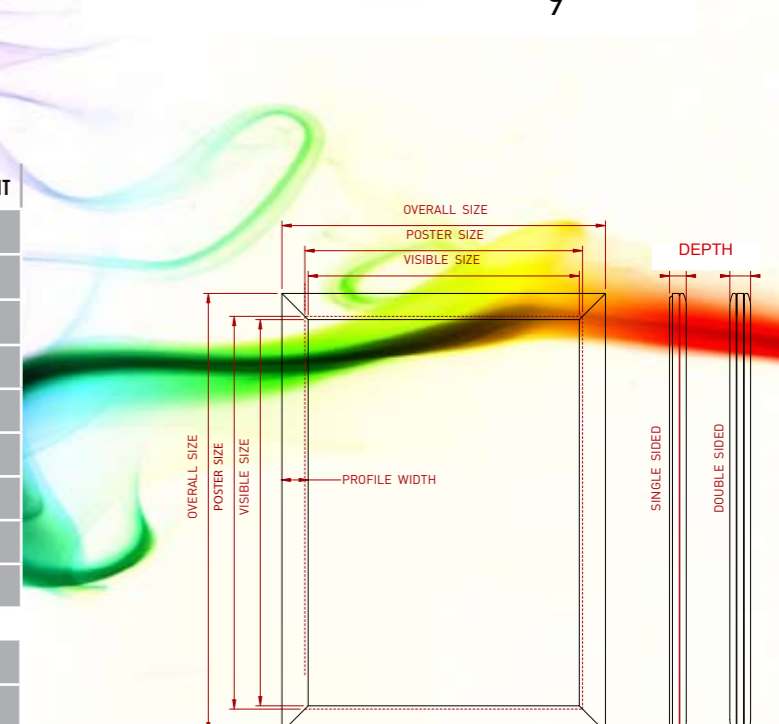



mounting holes
 trous de montage
 montagegaten
 Befestigungslöcher



cable exit
 sortie du câble
 kabeluitgang
 Kabelausgang



reflector profile
 profilé de réflecteur
 lampreflectorprofil
 Reflektorprofil

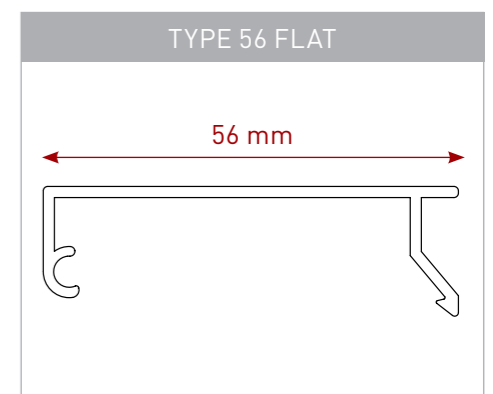
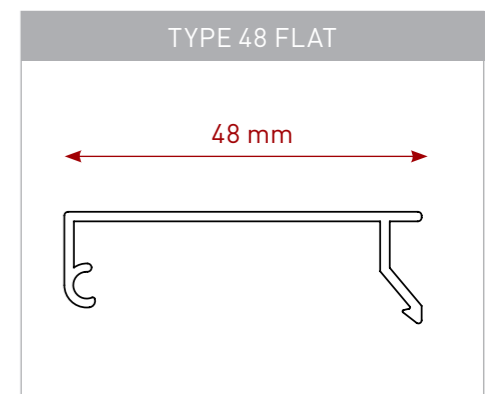
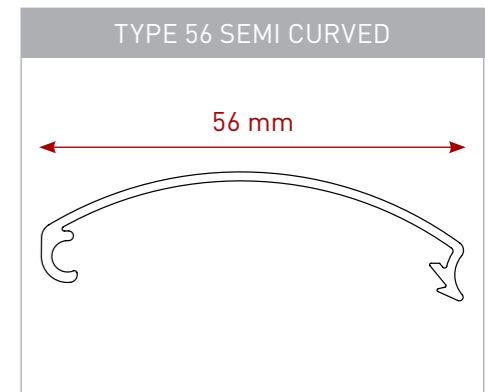
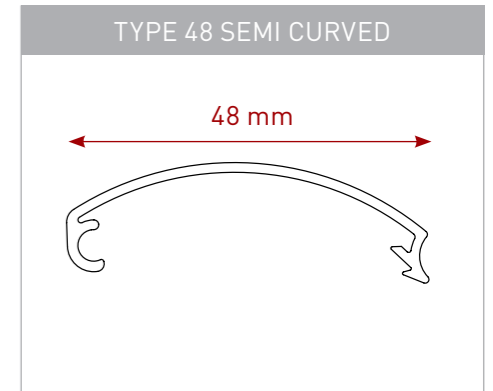

profile types (scale 1:1)
 types de profils (échelle 1:1)
 profielsoorten (ware grootte)
 Profiltypen (Massstab 1:1)

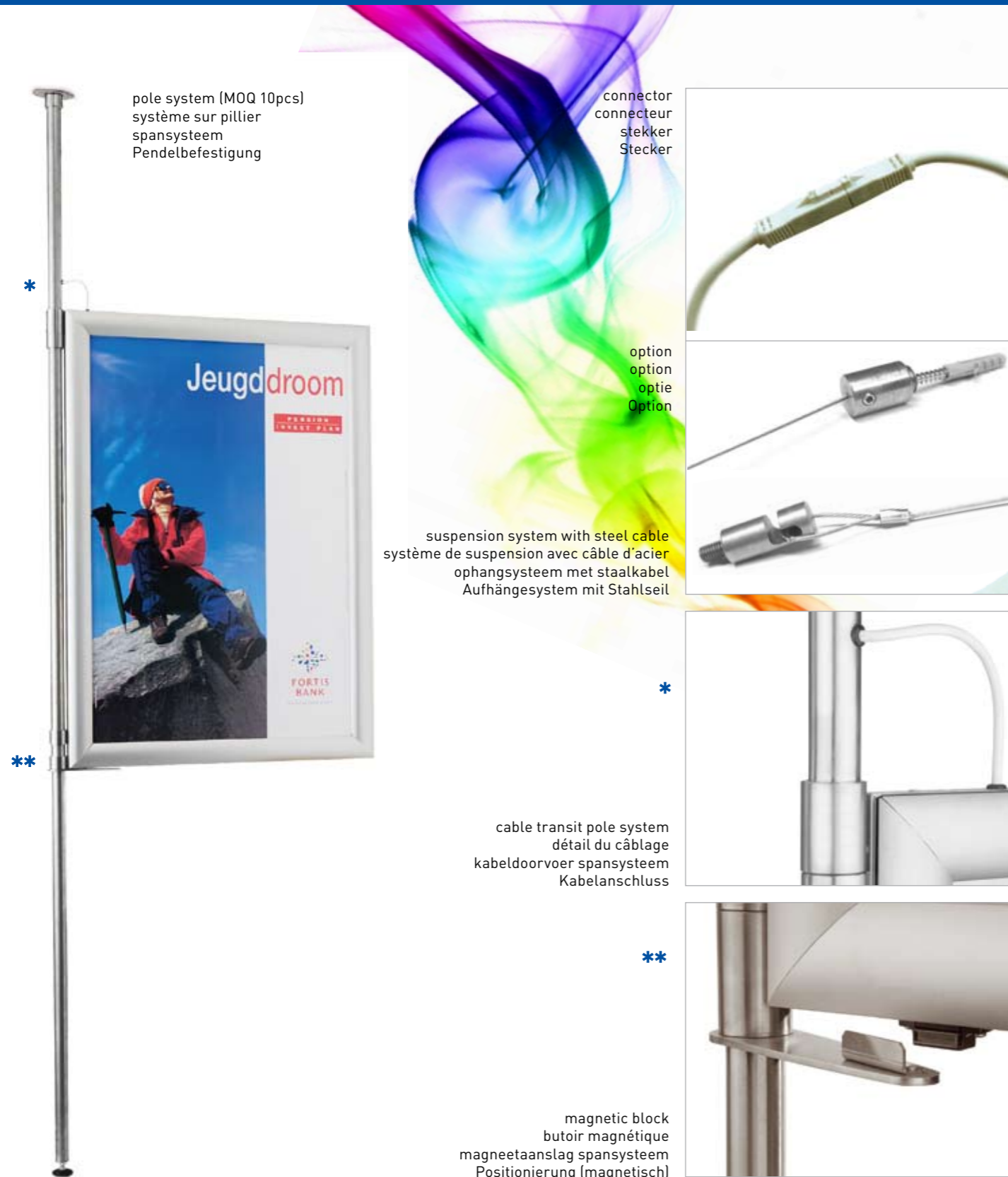

MOUNTING
MONTAGE
PLAATSING
MONTAGE

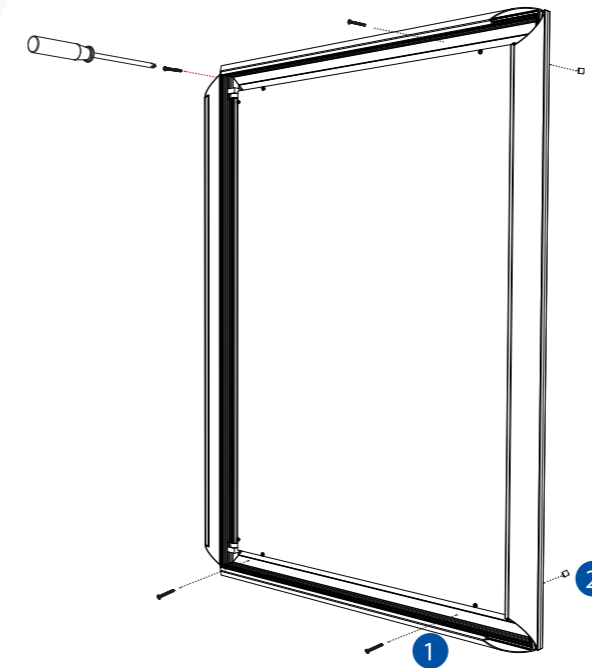

EN

WALL MOUNTING (INSTALLATION)

1. Open the click profiles and use the 4 mounting holes to screw the frame against the wall.
2. During the installation 4 spacers will be put over the screws in between the frame and the wall.

POSTER CHANGE

- a. Open the click profiles.
- b. Position the poster in the base profile. Put the cover sheet on the poster with the non-reflective side up.
- c. Close the click profiles.

FR

MONTAGE

1. Ouvrez les profilés clics.
2. Fixez le cadre contre le mur par les 4 trous dans le profilé de base.

CHANGEMENT DE L'AFFICHE

- a. Ouvrez les profilés clics.
- b. Placez l'affiche dans le profilé de base. Mettez la feuille de protection sur l'affiche avec le côté antireflet vers l'extérieur.
- c. Fermez les profilés clics.

POSTER CHANGE
CHANGEMENT DE L'AFFICHE
POSTERWISSEL
POSTERWECHSEL

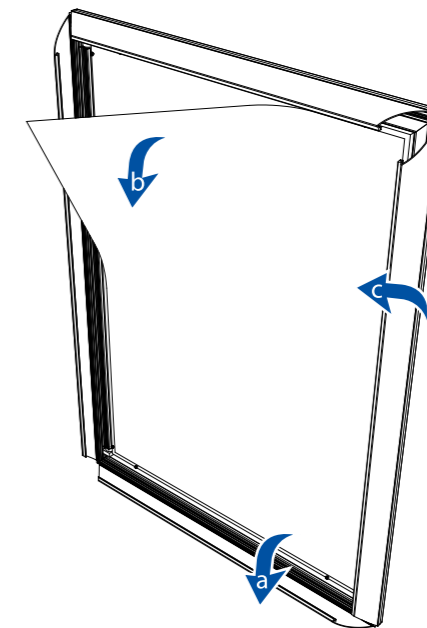

NL

PLAATSING

1. Schroef de opengeklikte kader tegen de wand via de 4 voorziene gaten in de hoeken.
2. Tussen lichtbak en wand worden 4 afstandhouders geplaatst over de schroeven.

POSTERWISSEL

- a. Open de klikprofielen.
- b. Wissel de poster en positioneer de poster met voorzetvel tussen de 4 alu profielen.
- c. Sluit de klikprofielen.

DE

WANDMONTAGE

1. Klappprofil öffnen. Rahmen durch die 4 Löcher an die Wand schrauben.
2. Benutzen Sie 4 Distanzhalter zwischen Rahmenrücken und Wand während der Montage.

POSTERWECHSEL

- a. Klapprahmen öffnen. Schutzfolie herausnehmen.
- b. Poster und Schutzfolie gemeinsam in das Trägerprofil einlegen. Matte Seite der Schutzfolie nach aussen.
- c. Klapprahmen schliessen.