

APPLICATIONS  
APPLICATIONS  
TOEPASSINGEN  
ANWENDUNGEN



Sabre Ultra Slim  
Sabre



- Easy to change the poster
- Indoor / Outdoor usage
- IP 66 rating
- Ultra flat
- Long life fluorescent lamps
- Corrosion free
- Access to poster with special key
- Even spread of light
- Low energy consumption
- Easy to install / easy to handle
- Different possible colour finishes
- Possible branding with logo





<b>1</b>	top profile (alu anodised) capot frontal (alu anodisé) voorprofiel (geanodiseerd alu) Frontrahmen (Alu eloxiert)	<b>2</b>	click profile (alu anodised) profilé clic (alu anodisé) klikprofiel (geanodiseerd alu) Klappprofil (Alu eloxiert)
<b>3</b>	base profile (alu) profilé de base (alu) basisprofiel (alu) Trägerprofil (alu)	<b>4</b>	fluorescent tube (T5) tube TL (T5) TL-lamp (T5) Leuchtstoffröhre (T5)
<b>5</b>	back panel (alu 1 mm) panneau de dos (alu 1 mm) rugpaneel (alu 1 mm) Rückwand (1 mm alu)	<b>6</b>	edge lit panel (PMMA) panneau central (PMMA) centrale lichtplaat (PMMA) Lichtstreuplatte (PMMA)
<b>7</b>	protection panel (polycarbonate) plaque de protection (polycarbonate) beschermlaat (polycarbonaat) Frontschutzplatte (polycarbonate)	<b>8</b>	hook crochet haak Haken

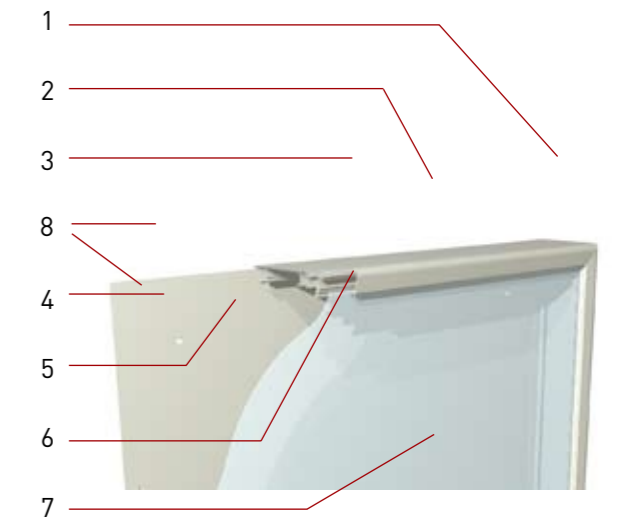

DIMENSIONS	
<b>VISIBLE SIZE</b>	HORIZONTAL: poster size - 8 mm VERTICAL: poster size -18 mm
<b>OVERALL SIZE</b>	HORIZONTAL: poster size + 92 mm VERTICAL: poster size +82 mm
<b>STANDARD POSTER SIZES</b>	POWDER COATED PROFILES ON DEMAND

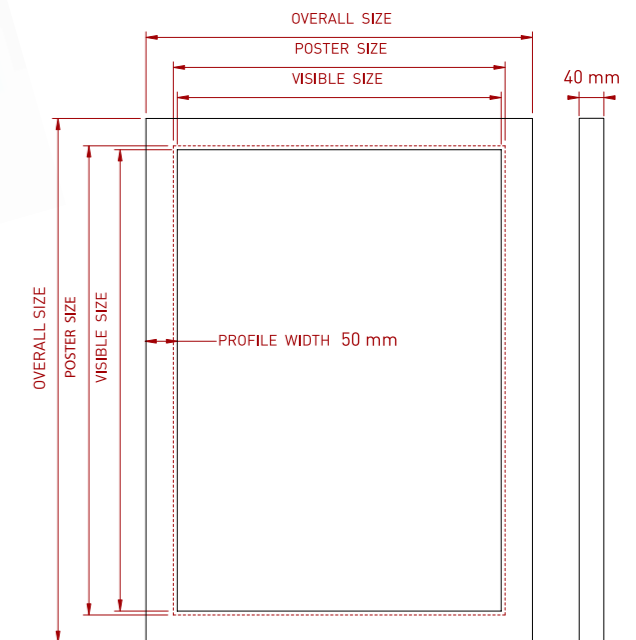



security lock (allen key)  
fermeture de sécurité (inbus)  
veiligheidsslot (inbus)  
Sicherheitsschloss (Inbus)



click profile  
profilé clic  
klikprofiel  
Klappprofil



rubber seal  
joints d'étanchéité en caoutchouc  
dichtingsrubbers  
Gummidichtung

hinging front panel  
charnière pour capot frontal  
scharnierend frontframe  
Scharnier für Fronthaube



hook for mounting on wall  
crochet pour montage au mur  
haak voor wandmontage  
Wandmontagehaken



MOUNTING  
MONTAGE  
PLAATSING  
MONTAGE

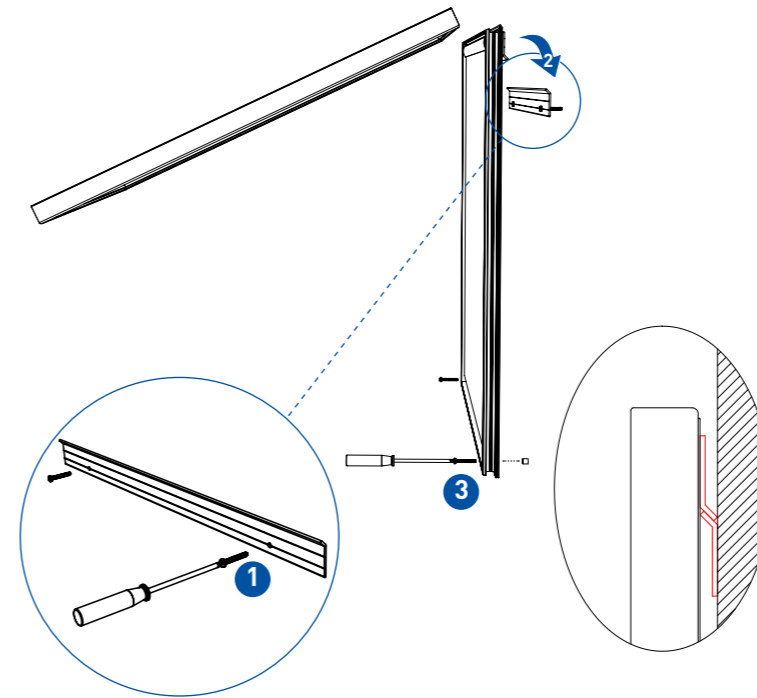

POSTER CHANGE  
CHANGEMENT DE L'AFFICHE  
POSTERWISSEL  
POSTERWECHSEL

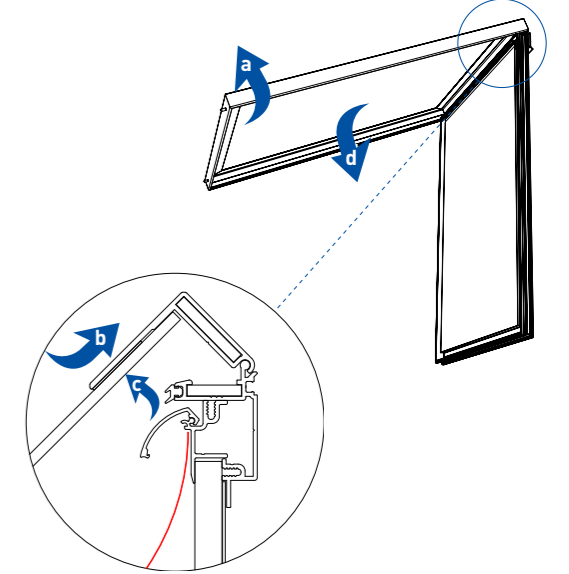

## EN

### MOUNTING

1. Screw the mounting hook on to the wall.
2. Hook the light box over the mounting hook.
3. Screw the light box at the bottom on to the wall through the mounting holes in the base profile using the spacers.

### POSTER CHANGE

- a. Unscrew the 2 security screws at the bottom.
- b. Lift the front panel (rotate).
- c. Open the click profile at the top and change the poster.
- d. Close the front panel and screw the 2 security screws

## FR

### MONTAGE

1. Vissez le crochet contre le mur.
2. Posez le caisson dans le crochet au mur.
3. Vissez le caisson avec des distanciers contre le mur par les trous du profilé de base.

### CHANGEMENT DE L'AFFICHE

- a. Dévissez les deux vis de sécurité.
- b. Décrochez le capot frontal.
- c. Ouvrez le profilé clic et changez l'affiche.
- d. Fermez le capot frontal et resserrez les deux vis de sécurité.

## NL

### PLAATSING

1. Schroef de muurhaak tegen de wand.
2. Haak de lichtbak in de muurhaak.
3. Schroef de lichtbak met afstandhouders onderaan tegen de wand door de gaten in het basisprofiel.

### POSTERWISSEL

- a. Draai de 2 schroefslotjes onderaan los.
- b. Open het voorprofiel (roteren).
- c. Open het klikprofiel bovenaan en wissel de poster.
- d. Sluit het voorprofiel en draai de 2 schroefslotjes terug in

## DE

### MONTAGE

1. Den Befestigungshaken an die Wand schrauben.
2. Den Leuchtkasten in den Befestigungshaken einhängen.
3. Den Leuchtkasten mit Distanzhalter an die Wand schrauben.

### POSTERWECHSEL

- a. Die beiden Sicherheits-schrauben (Inbus) lösen.
- b. Die Fronthaube abnehmen.
- c. Das Klappprofil öffnen - Poster wechseln - Klappprofil schliessen.
- d. Sicherheitschrauben wieder anziehen.

